



Annual Meeting
March 23-25, 2003
Marriott Rivercenter Hotel
San Antonio, TX

AM-03-13

Innovative Technology Meets Processing and Environmental Goals: Flying J Commissions New MSCC and TSS

Presented By:

Vincent J. Memmott
General Manager for
Refining, Processing and
Engineering
Flying J Inc.
North Salt Lake, UT

Bruce Dodds
International Alliance
Group (IAG)
Houston, TX

This paper has been reproduced for the author or authors as a courtesy by the National Petrochemical & Refiners Association. Publication of this paper does not signify that the contents necessarily reflect the opinions of the NPRA, its officers, directors, members, or staff. Requests for authorization to quote or use the contents should be addressed directly to the author(s)

**Innovative Technology Meets Processing and Environmental Goals:
Flying J Commissions New MSCC and TSS**

VINCENT J. MEMMOTT
GENERAL MANAGER FOR REFINING, PROCESSING AND ENGINEERING
FLYING J REFINERY

BRUCE DODDS
INTERNATIONAL ALLIANCE GROUP (IAG)

**Presented at
NPRA
2003 National Meeting
March 23-25, 2003
Marriott Rivercenter Hotel
San Antonio, TX**

Innovative Technology Meets Processing and Environmental Goals: Flying J Commissions New MSCC and TSS

Abstract

Big West Oil LLC's Flying J refinery is a supplier of transportation fuels and waxy feedstocks in the Intermountain West region and throughout the United States. In an effort to more efficiently utilize the available crude mix, Flying J recently started up a grassroots MSCC unit. With the installation of the catalytic cracking unit, Flying J was required to install a flue gas cleaning technology that could meet EPA NSPS regulations. The technology chosen by Flying J for the removal of particulate matter from the MSCC flue gas was the UOP™ Third Stage Separator (TSS).

The installation of the UOP TSS in a strictly environmental capacity is a departure from the traditional role of the TSS as protection for a power recovery expander. Flying J moved forward with the project recognizing that newly developed technology was being commercialized. The MSCC performance has been very satisfactory and the TSS has succeeded in meeting, and exceeding, EPA requirements for particulate emissions from the MSCC unit. The decreased costs associated with installing the TSS, when compared with other flue gas cleaning technology, and the improved yields from the MSCC have resulted in an improved refinery position of \$1.60-\$1.70 per barrel of crude charge. The close cooperation between Flying J, the process licensor UOP, and IAG who managed the project, contributed to a cost effective project with a simple payout of 25 months.

Background

The Flying J refinery, located in North Salt Lake, Utah, was built in 1948 with a crude processing capacity of 500 barrels per day. The refining capacity increased several times over the next 14 years, and in 1962 the TCC catalytic cracking unit and HF Alkylation unit were constructed.

The current crude capacity of the refinery is 25,000 barrels per day. The refinery consists of crude and vacuum distillation, naphtha hydrotreating and reforming, C₅/C₆ isomerization, Butamer and saturates gas plant, catalytic cracking, HF alkylation, diesel hydrotreating, fuel gas scrubbing and sulfur recovery.

Recent Operation

The Flying J crude slate is made up of a mixture of 40% high paraffin Utah Wax Crude, 40% Southwest Wyoming Light Crude and 20% Canadian Syncrude. The crude unit at Flying J is block operated to process yellow wax crude separately. Virtually all of the heavy material in the yellow wax crude is recovered in the vacuum unit for specialty use. The feed to the catalytic cracker is atmospheric bottoms from the crude distillation unit. The refinery products are primarily gasoline and low sulfur diesel. Wax distillates, which are sold as a feedstock for specialty wax products, comprise approximately 10% of the product slate. The refinery is also a net seller of isobutane to the other refineries in the Salt Lake City area. A small amount of slurry oil is sold as fuel oil.

Flying J had been wrestling with the idea of installing a Fluid Catalytic Cracking Unit (FCC) for some time, but in the 1980's and 1990's it was difficult to justify replacing the TCC with an FCC Unit. The volume of crude oil available in the Salt Lake City area was declining during this period and TCC operation was close to what the expected FCC operation would be on the available feedstock.

Due to the low levels of cat feed from the crude charge, prior to 2002, the TCC operated at less than design capacity for several years. During this period of low cat feed volumes, the availability of another crude, a Utah wax crude known as black wax, started to increase. The black wax was relatively high in metals and con-carbon. Through a series of test trials it was determined that the refinery could not maintain stable TCC operation when processing any significant amount of the black wax. Flying J decided that the TCC did not provide the flexibility that was needed to economically process the atmospheric bottoms from black wax crude.

Additionally, in the late 1990's, the completion of the Express Pipeline from Northern Alberta to Casper, Wyoming made Canadian crudes, including Syncrude, available to refiners in the Salt Lake City area. Flying J's experience with the Syncrude also demonstrated the need for more flexibility in the catalytic cracking unit. In late 1997 Flying J approached UOP for an estimate of the product yields from a fluidized catalytic cracker utilizing the proposed future feedstock. It became apparent to Flying J that there were significant economic opportunities associated with processing more black wax and Syncrude, and upgrading the catalytic cracking technology.

Revamp Scope

Once the upgrading of the TCC to a fluid catalytic cracker was found to be economically justified, Flying J set out to identify the complete project scope so that project timing and capital expenditures could be determined. In early 1998 Flying J contracted UOP to provide a revamp feasibility study to determine the effects of the new product distribution on the main fractionator and the gas concentration unit.

The feasibility study showed that with relatively minor modifications to the main column and gas concentration section, a new fluid catalytic cracking unit could be installed with a design throughput of 8,000 barrels per day. At this point Flying J brought International Alliance Group (IAG) on board to provide detailed cost estimates and overall project management. Flying J had decided that a capital investment, based on hard economics, should be limited to \$24,000,000 for the new cracking unit and ancillary unit modifications. This was based on a projected increase in product margin of \$8,000,000 per year. If, after reviewing the proposed revamp scenarios, the product margin increased significantly, a greater capital expense would be accepted.

Over the next two years Flying J worked with IAG and UOP to set the project scope and to complete the engineering on the proposed modifications. The initial scope of the project included;

- Replacing the reactor/regenerator structure of the TCC with fluid catalytic cracking technology
- Installation of an Electrostatic Precipitator (ESP) for removal of catalyst fines from the catalytic cracker stack
- Installation of a stub column upstream of the main fractionator to desuperheat the reaction vapors
- Upgrading of the combustion air system to allow for more coke burn
- Re-rating of the wet gas compressor
- Re-traying of columns, replacing of pumps and rearrangement of the heat integration in the gas concentration section

Several obstacles were discovered once the initial scope of the project was determined. First, a +/- 30% cost estimate by IAG showed that the capital investment would be between \$20,000,000 for a bare bones revamp and \$27,000,000 for a truly operational unit. Second, the plot space was going to be very tight for the installation of a new stub tower and an ESP downstream of the catalytic cracking unit regenerator.

Innovative Technology

In order to take the project to the next phase some of the cost and space issues had to be settled. The decision was made to completely replace the main fractionator, rather than adding a stub tower upstream of the old fractionator. This resulted in eliminating an additional 8'-6" diameter, 24' tangent to tangent tower. The other item to be addressed was the ESP.

UOP TSS

Soon after the feasibility study was issued and the initial scope put together, UOP announced that they had a new TSS offering that would meet the EPA NSPS requirements of 1 lb of particulates emitted per 1,000 lbs of coke burned in the

regenerator. The benefits of utilizing this technology were immediately evident to Flying J.

- The plot space requirement would be significantly reduced
- There would be virtually no operations monitoring required
- The hazards associated with operating an ESP would be eliminated
- The capital cost of the TSS unit was \$1,600,000 less than the estimated ESP cost

The TSS was by far the largest unknown in the revamp equation. Flying J had evaluated all the technologies available for complying with NSPS emission standards and were anxious to investigate new opportunities. After several meetings discussing the UOP technology development program and how it differed from other TSS offerings, which are mainly used for expander blade protection, it was decided that the benefits of installing a piece of mechanical equipment, rather than a stand-alone flue gas cleaning process, outweighed the risk-factored downside. Flying J committed to installing the first UOP TSS (Figure 1).

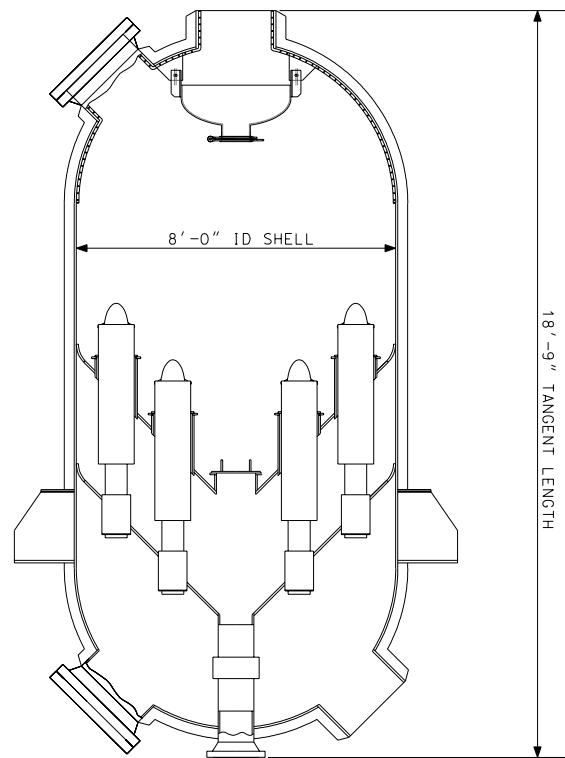

Figure 1: UOP TSS at Flying J

The TSS is installed in the structure between the flue gas cooler and the orifice chamber on a 24" flue gas line. The TSS unit included an underflow filter system, in a bag house configuration, to capture the fines from the constant underflow.

The underflow filter is installed at ground level and at the base of the reactor and regenerator structure on a 12' by 12' plot space (Figure 2). The cleaned gas from the underflow filter is returned back to the MSCC stack.

MSCC

When Flying J made the decision to upgrade the TCC unit to a fluid catalytic cracking unit we weren't sure what the best technology for the operating goals would be. Several options were investigated including;

- FCC unit with combustor style regenerator
- FCC unit with two-stage regeneration
- FCC unit with bubbling bed regenerator
- MSCC unit

The initial technology analysis left us with two options, either the FCC unit with a bubbling bed regenerator or the MSCC unit. The MSCC unit could be built with either a combustor style or bubbling bed regenerator and would occupy a smaller footprint.

After a thorough evaluation of cost, yield and performance issues, we decided to move forward with the MSCC unit. The Flying J MSCC was to be the first grass roots MSCC in the United States.



Figure 2: TSS Underflow Filter

The project was now ready to move forward. Flying J met with IAG and UOP for a project kick-off meeting at the end of 1998 with a planned start-up of the new catalytic cracker (Figure 3) in the first quarter of 2002.

Project Timing

After the kick-off meeting at the end of 1998 the revamp scope was finalized in the first half of 1999. Engineering and planning for the revamp started in earnest in the first quarter of 2000. The UOP Schedule A package was completed in August 2000.

The project was executed so that the new reactor/regenerator structure and support facilities were completed before the TCC unit was shutdown. Field inspection began four months before the turnaround. The TCC unit was shutdown on March 30, 2002 and work to tie the MSCC into the feed system and the main fractionator was started.

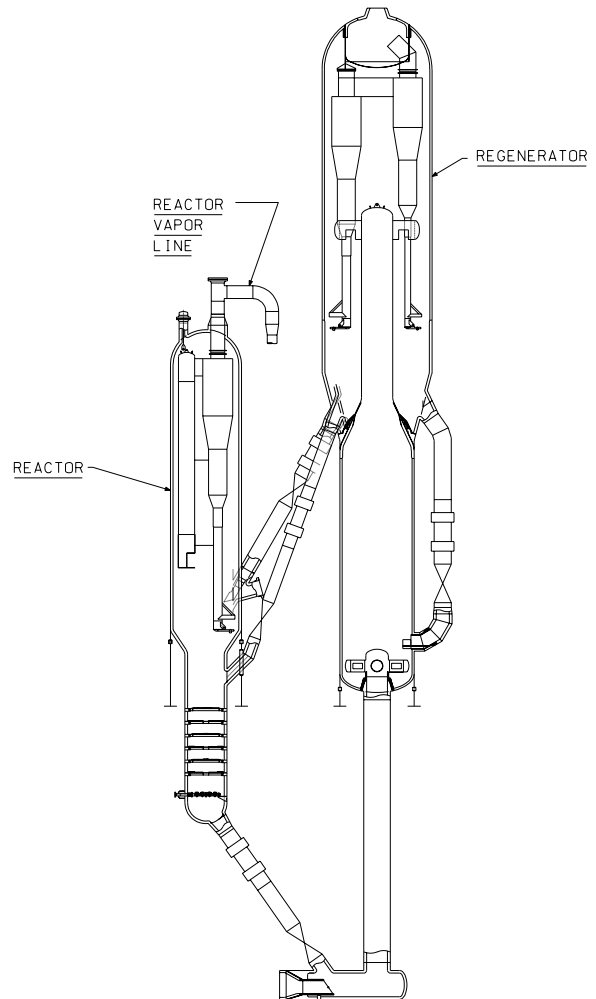

Figure 3: MSCC Reactor - Regenerator

It took just under one month to complete all of the work around the wet gas compressor and the gas concentration section and to tie the MSCC into the existing feed system and the main fractionator. As the TSS was shop fabricated and delivered as a complete package, field work associated with installing the TSS was minimal.

Feed was introduced to the unit on April 29, 2002. It took about one week to line out the system and reach stable operation.

Technology Performance

MSCC

After the startup of the unit we entered into a testing and optimization program to prove the effectiveness of some of the MSCC features. Of the several attractive features on the MSCC, the hot stripper with variable catalyst level and the heavy cycle oil recycle location have proved to be particularly meaningful to our maximum Gasoline + LCO operation.

The MSCC technology combines the advantages of quick contact and catalyst disengaging for the easier to crack feed molecules with longer residence time requirements of the larger hydrocarbon molecules. This “Dual Reaction Zone” configuration is a characteristic of the MSCC operation. The larger molecules that do not crack in the highly selective quick-contact zone at the feed injection point continue into the dense phase of the stripper where they see a more severe cracking environment. The increased severity in the stripper is facilitated by the recycle of hot catalyst from the regenerator directly into the stripper, a feature unique to the MSCC process (Figure 4).

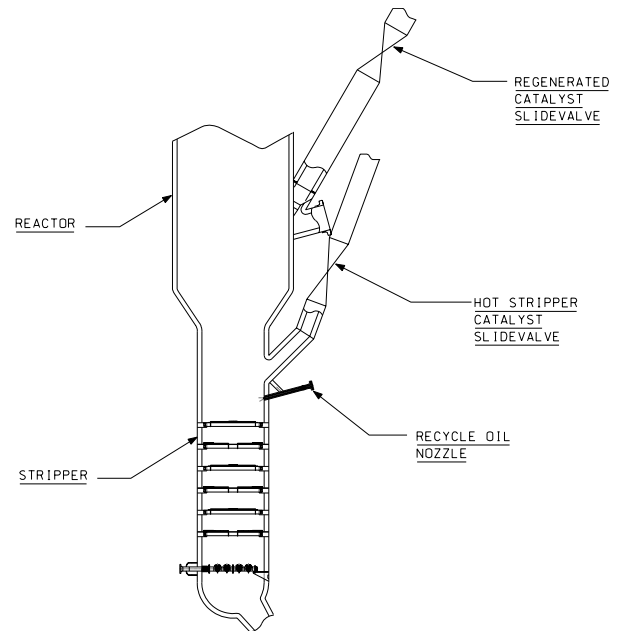

Figure 4: Flying J MSCC Stripper

Varying the level in the stripper had a significant impact on the product yields, while still maintaining an acceptable stripping efficiency. The stripper in the MSCC unit consists of six stripping stages of the “grating with downcomer” configuration, an advanced stripping tray design from UOP. The MSCC unit was the first unit in the United States to commercialize this type of stripper baffle. The new stripper configuration maintained good performance throughout the optimization and testing of the unit. The data in Table 1 is representative of the changes that were observed as the catalyst level in the stripper section was varied.

Stripper Catalyst Level, ft	Base	-4
Stripper Temperature, °F	975	977
C ₂ -, wt-%	2.6	2.4
LPG, LV-%	27.8	28.3
Gasoline + LCO, LV-%	77.1	78.1

Table 1: Stripper Level Affect on Product Yields

A significant increase in gasoline and overall liquid yield was achieved as the stripper level was lowered.

Since processing objectives are for maximum gasoline and LCO production, recycling some of the heavier material back to the reactor is standard procedure. The MSCC design provided three options for injecting the recycle. They included recycling back to the fresh feed in the feed distributor, recycling to a dedicated nozzle in the feed distributor and injecting the recycle into the dense bed of the reactor stripping section. Each of these options was explored in the optimization tests.

There was a measurable improvement in yield when the recycle was injected into the dense phase of the reactor stripper. However, as discussed above, there was also a yield benefit in reducing the catalyst level in the stripper. The benefit from reducing the catalyst level in the stripper outweighed that of injecting the recycle to the stripper.

When the catalyst level was reduced to its optimum point in the stripper, the recycle distributor in the stripper was above the catalyst level. This eliminated the option of injecting the recycle feed directly into the stripper. Flying J intends to explore the possibility of lowering the recycle feed distributor in the next turn around to take advantage of the potential yield benefit.

Although injection of the recycle into the stripper catalyst bed appeared to result in the greatest yield improvement, there was also a measurable yield improvement in combining the recycle with the fresh feed rather than injecting the recycle through a dedicated feed nozzle. Table 2 shows the yield difference between combined and dedicated injection of the recycle feed.

	Combined Feed	Dedicated Feed
Stripper Temperature, °F	956	951
C ₂ -, wt-%	2.6	2.6
LPG, wt-%	12.9	12.8
Gasoline + LCO, wt-%	72.3	71.5
Slurry Oil, wt-%	5.6	5.7

Table 2: Recycle Location Influence on Product Yields

It is also interesting to note that early optimization testing at a lower feed rate indicated that feeding the recycle to the dedicated injection nozzle resulted in a yield improvement over the combined feed injection. We speculate that the lower feed rate, and the resultant lower pressure drop across the distributor, likely resulted in poorer mixing between the catalyst and the feed. In any event, the MSCC has provided the flexibility to change how the recycle is injected. Optimization testing will be conducted periodically to determine how the recycle should be injected in order to maintain the most profitable yields.

In addition to the optimization and testing program, a guarantee run on the MSCC was completed in June 2002. The unit was run in the guarantee mode of Maximum

Gasoline + LCO. The unit was accepted, with all guarantees being met, on June 27, 2002. A comparison of product yields before and after the revamp is in Table 3.

	Pre-Revamp (TCC)	Post-Revamp (MSCC)
Dry Gas, wt-%	4	2
Alkylation Unit Feed, LV-%	16	21
Gasoline + LCO, LV-%	74	85
Main Column Bottoms, LV-%	11	4

Table 3 – Before and After Unit Product Yields

The MSCC unit is currently running at over 8,000 bpsd with an available capacity of 10,000 bpsd. The built in flexibility of the unit and ease in which it operates has proven to be another significant benefit over the TCC unit.

TSS

After the MSCC unit guarantees were accepted attention was placed on the operation of the TSS unit. It was immediately apparent that the TSS and underflow filter were performing exceptionally well as evidenced by the low opacity of the MSCC stack.

Initial testing on the TSS unit occurred in September 2002. The testing included taking several samples at various flue gas rates. Results from the initial testing showed that the stack particulate levels varied from 38-50 mg/Nm³, depending on unit turndown rate.

Final compliance testing took place in December 2002. The tests confirmed that the TSS has allowed Flying J to meet the current NSPS standards. In fact, the particulate emissions measured were only about 60% of that allowable by the NSPS standard of one pound per 1,000 pounds of coke burned.

Project Results

The overall project was a complete success. The final cost of the project was approximately \$33,000,000. This included \$27,000,000 for the MSCC portion of the project and \$6,000,000 for the changes to the fractionation system and other miscellaneous tasks.

Based on economics of the past year the estimated gross improvement in revenue from the MSCC project is about \$16,000,000 per year. This represents a projected simple payout of 25 months and a net improvement in the refinery position of \$1.60 - \$1.70 per barrel of crude charge, based on 2002 feed and product values.